

Fabricator's Handbook



The look and feel of natural stone,
but so much more durable and
easier to maintain.



Heat resistant

High heat resistance. Suitable for use around cooktops.



Stain resistant

No risk of staining - even with red wine or makeup.



Hardness

Diamond polished surface for scratch resistance.



Easy clean

Easy clean, non-porous surface. Clean with any household cleaners.



Hygienic

Non-porous for a bacteria free surface.

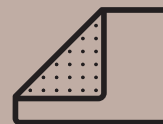

Repairable

If scratched or damaged can be easily repaired in-situ with fine sandpaper and polish.

Fabricator's Handbook

Prior to undertaking any activities involving SilkSurface and SilkSurface adhesive, it is mandatory to review this document thoroughly and adhere to the specified procedures.

- 2 Receiving, storage and handling
- 3 Machining – recommended tooling and equipment
- 4 Picking your colours and matching slabs
- 5 Joining and seaming
- 8 Built up edges
- 12 Supports and subframes
- 14 Cutouts
- 14 Finishing and polishing
- 15 Transportation, site preparation and installation
- 16 Repair
- 17 Why we get colour variation in the solid surface industry
- 17 Versatile applications
- 17 The SilkSurface University



FREE SilkSurface training
for your business, see
page 17 for details.

Receiving, storage and handling

Receiving

- Confirm arrival in good condition: SilkSurface is carefully packed by our Dispatch team and is shipped in such a way as to minimise the risk of in-transit damage. Please unwrap your shipment and carefully check the integrity of your SilkSurface sheets within 24 hours of arrival and report any damage or inconsistencies immediately. This is an essential requirement for any warranty claims relating to a damaged shipment.

Storage - Slabs

- SilkSurface Slabs must be stored correctly to prevent warping or damage.
- SilkSurface must be stored under cover in a dry, well-ventilated area with no exposure to moisture or direct sunlight. SilkSurface has a thin plastic film to protect the face which should be left on during storage. Do not store or stack other items on top of SilkSurface that may cause damage to the product.
- Each SilkSurface slab has the colour and batch number noted on the edge or underside of the slab; it is recommended that slabs are stored in a way this information is easily visible.
- SilkSurface slabs 650mm/950mm wide must be stored flat or vertically supported to be straight. 1600mm wide slabs should be stored only vertically.
- Bowing or warping is usually caused by improper storage practices. Products should not lean against walls or structures.

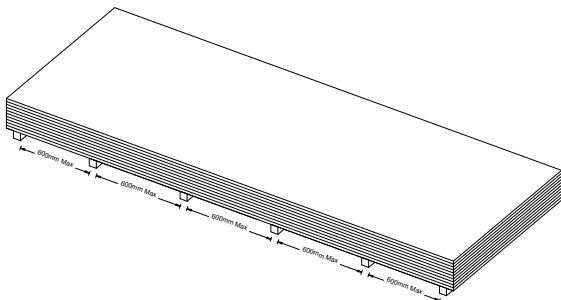

Horizontal storage of SilkSurface is recommended, on a flat and level surface supported evenly across the length of the slab (maximum 600mm spacing between supports). All supports must run the full depth of the slab.

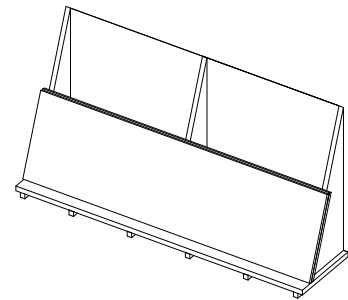

If stored vertically (Eg. on an 'A Frame'), there must be a minimum of 3 supports across the length of the slab with the vertical supports running the full slab depth.

Storage - Adhesives

SilkSurface adhesives should be stored under cover in a dry, well-ventilated area with no exposure to moisture or direct sunlight. It is recommended that adhesives are stored between 10-20 degrees Celsius to achieve maximum shelf life (24 months).

Handling

It's recommended that SilkSurface slabs are lifted with a forklift or other mechanical lifting equipment suitable for weights below:

Slab Length	Slab Depth	Slab Thickness	Slab Weight	Pallet Weight	Weight per square metre
3200mm	650mm	20mm	93.6kg	20 Slabs – 1870kg	45kg
3200mm	950mm	20mm	136.8kg	10 Slabs – 1368kg	45kg
3200mm	1600mm	20mm	230.4kg	15 Slabs – 3500kg	45kg

If manually handled, do not attempt to lift multiple SilkSurface slabs, wear the correct personal protective equipment (gloves, steel cap boots etc.) and follow heavy load manual handling practices. Ensure that the SilkSurface slab is carried vertically and is well supported for the duration of the lift as carrying SilkSurface horizontally may cause the Slabs to flex and warp. Never push or drag SilkSurface along the ground as this will likely cause damage to the edge of the slab.

Any claim for faulty or damaged goods must be made within 48 hours from receipt of product. Any warping or damage caused by incorrectly storing or handling SilkSurface will not be covered under warranty.

Machining – recommended tooling and equipment

SilkSurface can be cut/machined using any of the following equipment:

- Waterjet Machine
- CNC Router
- Beam Saw
- Table Saw
- Hand router

For saw blades and router bits, while tungsten carbide tipped tools are sufficient, diamond tipped tools are recommended for the highest quality cut/finish and longest tool life.

Tooling must be kept sharp and clean to prevent chipping or other damage to SilkSurface. Speak to your tooling supplier as to the best feed speeds/rotation speeds for your machinery.

The below details can be used as a general power guide for routers:

- General Cutting/Machining: Minimum 2200W
- Edge Trimming/Seam Trimming: Minimum 1400W
- Edge Finishing (Rounding or Chamfering edges): Cordless trimmers are sufficient.

For general cutting/machining with a CNC Router, the table below from an existing SilkSurface fabricator can be used as a guide:

Router Tool	13mm Carbide shank PCD Straight Cutter, 2 Flute, 5 degree upshear (No upshear can result in a lower quality edge finish)
Machining Details	
Feed Rate:	2000mm/Min
Descent Rate:	1000mm/Min
Spindle Speed:	18000 rpm
Rotation Direction:	Clockwise
Number of Passes:	2
Lead In/Lead Out Length:	50mm

In the example above, a finishing tool is used for both machining passes. However, a 'roughing' tool can be used to remove material more quickly before the edge is completed with a 'finishing' tool.

Roughing Tool	Finishing Tool
Higher feed rate	Lower feed rate
Higher cutting depth	Lower cutting depth (More passes may be required)
Lower quality surface finish	Higher quality surface finish
Higher chip load on the tool	Lower chip load on the tool
Higher material removal	Lower material removal
Lower dimensional accuracy	Higher dimensional accuracy

Fabricator's Handbook

When using Saw blades to cut SilkSurface, the blade should have a minimum of 7 teeth per 25mm diameter, have a 'triple chip grind' and a rake angle between -5 and 10 degrees to prevent chipping and achieve the best possible finish. For dry cutting with a saw blade the below example from an existing SilkSurface fabricator can be used as a guide:

Saw Blade	180mm Diameter, 3.2mm thick, 54 Tooth PCD Solid Surface blade
Machining Details	
Feed Rate:	4800mm/Min
Descent Rate:	1000mm/Min
Rotation Speed:	8000 rpm
Number of Passes:	1
Lead In/Lead Out Length:	40mm

Tooling

The following tools can be used to cut/machine SilkSurface, however take extreme care to fit the correct blades to prevent chipping:

- Jig saw
- Ripping/Combination saws
- Hacksaws or other types of manual hand saws

When machining SilkSurface slabs down to size, it is important to consider any allowances that need to be made for joining, built-up edges or onsite trimming. For example, certain built-up edges such as 'Drop Edge – Rebate' require the SilkSurface top to be 1mm oversized on each built up edge (refer to 'Joining SilkSurface' and 'SilkSurface Built Up Edges' sections).

Random orbital sanders with a minimum 125mm sanding disk should be used for finishing/polishing SilkSurface. Belt sanders may be used to scribe tops when placed against walls but should not be used to polish.

Clamp types depend on the application and the user's preference. However, a Slab Seam setter can assist in joining and levelling SilkSurface.

SilkSurface is non-toxic and contains 0% Silica. However, as is the case with any dust producing operation, exposure to dust may cause irritation and pose a safety risk. The correct dust extraction and personal protective equipment (PPE) must be used to ensure a safe working environment.

SilkSurface can be manufactured with the same machinery and tooling used for engineered stone, such as CNCs, bridge saws, and edge polishers. This has been tested and confirmed by several trusted stone machinery manufacturers. We recommend ordinary woodworking equipment such as CNC's, table saws, planers, hand routers etc.

Picking your colours and matching slabs

Matching of slabs before manufacture or taking to site to install is crucially important. Joins should always be picked with care: especially in the Infinity range where the colour and patterns will need to be lined up.

We highly recommend you lay your slabs out before any manufacture of the product, to mimic the benchtop plan of the job to check colour and patterns line up. Manufacture of the product is acceptance of the product. This is industry standard.

PHOTO: Full size photo of SilkSurface slab with three samples showing where they fit into the slab and why samples can vary from the full slab.



Joining and seaming

For fabricators who have not worked with SilkSurface, SilkSurface adhesive or used a certain join method previously, it is recommended that small offcuts are used to test your preferred join to ensure production can be completed smoothly for larger pieces.

There are several important details to consider when joining SilkSurface:

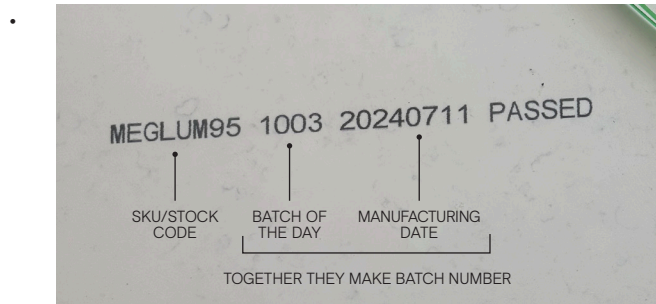
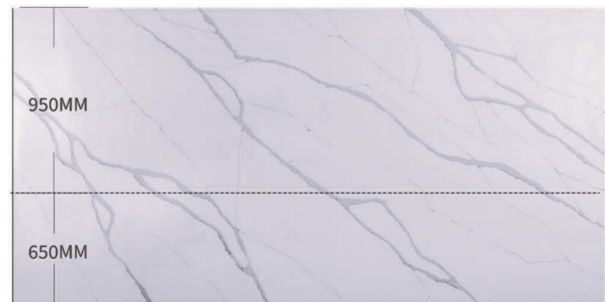

PHOTO: Refer above on how to read batch numbers.

- Number and position of seams (joins) to maximise slab yield.
- Position of seams in relation to cutouts (E.g. Sinks or cooktops) – If possible, cutouts should be positioned at least 75mm from any seam.
- Which joining method should be chosen to best suit the veining/pattern of the chosen SilkSurface colour, the application and the tools that are available.

- Which seams can be done as part of factory fabrication, and which will have to be done onsite.
- Which tools/equipment are required to achieve the desired join.
- We recommend sanding and polishing joins upon installation.
- It is up to the fabricator to find the best match for the slabs to join, before cutting of the slabs and installation. This is industry standard.
- Masons mitre is a typical join that takes away from any variation within the slabs – or that looks to be different. All areas to be joined need to be cleaned to prevent contamination & discoloration of the joint.
- Toggles can be used to join SilkSurface EXCEPT in translucent colours, as they may be visible through the material.

For SilkSurface colours with a defined veining pattern. The veining/pattern will run diagonally across the sheet at approx 45 degrees.



Joining Methods

The following diagrams show the most common joining methods for SilkSurface (with Vein direction indicated):

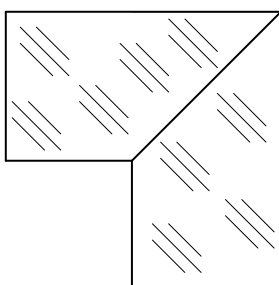

**L Shape Join
(45 degrees)**

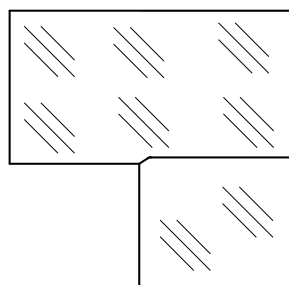

**L Shape Join
(90 degrees - Masons Mitre)**

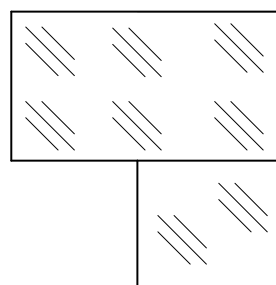

**L Shape Join
(90 degrees - Standard
Butt join)**

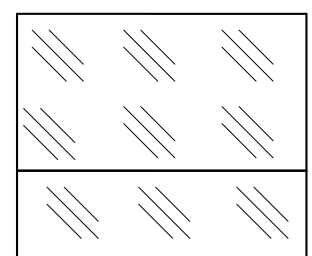

**Side to Side Join
(Increasing the width of a
SilkSurface Slab)**

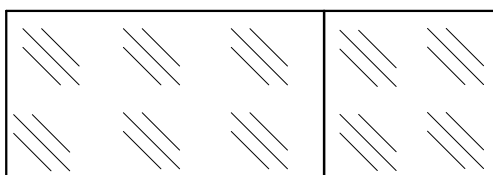

Butt Join

Preparing SilkSurface slabs for joining

For SilkSurface to be joined correctly, a clean edge free of damage or chipping is required. If a clean edge for joining cannot be achieved during the initial machining process (E.g. a saw cut may leave a slightly uneven finish), then the following cutting procedures can be used to create the required edge finish.

Mirror cut

This method involves routing the edges of both SilkSurface slabs to be joined at the same time.

Equipment:

- Hand router
 - Straight edge or router guide.
 - Clamps (to hold slabs to work surface and straight edge/router guide to SilkSurface)
 - Double fluted 12mm router bit as per tooling recommendations (other diameter bits may be used but ensure the Slabs to be joined are repositioned as require so the necessary amount of material is removed).
1. Ensure the SilkSurface slabs to be routed are on a flat and level surface with support across the full length of the top. Clamp the slabs in place on the work surface leaving a gap of 9mm between them.
 2. Clamp a straight edge/router guide onto one of the SilkSurface slabs to ensure a straight route. Make sure clamps are positioned to allow router to move along the length of the seam.
 3. Double check the Slabs and straight edge are aligned and in the correct position.
 4. Moving slowly but continuously, move the router along the straight edge removing 1.5mm of material from each slab.
 5. Ensure all dust and excess material is removed with a lint free white rag and methylated spirits.
 6. Remove clamps and straight edge.
 7. Test fit the two slabs together before moving onto the next steps of preparing the edge and applying adhesive.

Single cut

This method involves routing each edge of the SilkSurface slabs to be joined separately.

Equipment:

- Hand router
 - Straight edge or router guide.
 - Clamps (to hold slabs to work surface and straight edge/router guide to SilkSurface)
 - Double fluted 12mm router bit as per tooling recommendations (other diameter bits may be used but ensure the Slabs to be joined are repositioned as require so the necessary amount of material is removed).
1. Ensure the SilkSurface slab to be routed is on a flat and level surface with support across the full length of the top. Clamp the SilkSurface Slab to the work surface.
 2. Clamp a straight edge/router guide onto one of the SilkSurface slabs to ensure a straight route and positioned so that 1.5mm of material will be removed.
 3. Double check the straight edge/router guide is aligned and in the correct position.
 4. Moving slowly but continuously, move the router along the straight edge removing 1.5mm of material from the slab.
 5. Repeat steps 1-4 for the second edge to be joined.
 6. Ensure all dust and excess material is removed with a lint free white rag and methylated spirits.
 7. Remove clamps and straight edge.
 8. Test fit the two slabs together before moving onto the next steps of preparing the edge and applying adhesive.

Preparing the edge before applying adhesive

1. Sand the edge to be joined with 120 Grit sandpaper to roughen it, making sure that the top edge remains sharp for a clean join. Repeat this step 2-3 times across the length of the join for both edges.
2. Ensure all dust and excess material is removed with a lint free white rag and methylated spirits.

Applying adhesive and joining SilkSurface

Always ensure that SilkSurface adhesive is used for joining SilkSurface slabs and that the adhesive colour chosen matches the SilkSurface.

1. All areas to be joined need to be cleaned to prevent contamination & discoloration of the joint.
2. Apply a clear tape or release paper along the work surface where the two pieces of SilkSurface will be joined (to prevent adhesive sticking to the work surface)
3. Ensure SilkSurface slabs are on a flat and level surface with support across the full length of the top.
4. Clamping is required to ensure the SilkSurface slabs are held together until the adhesive cures. A 'Seam setter' clamping system is the most efficient method. Alternatively, affix temporary clamping blocks along the join on the bottom of the SilkSurface slabs with a hot melt glue gun. G Clamps can then be fixed to these temporary clamping blocks once clamping is required.
5. Ensure SilkSurface tops are aligned and positioned approximately 5mm apart.
6. Cover edge openings with clear tape to prevent adhesive leaking from seam.
7. Apply SilkSurface adhesive evenly along the entire face of the join on one edge (A minimum 3mm thick bead is required).
8. Move SilkSurface slabs together so that an even bead of adhesive is forced out along the entire length of the join. If there are areas SilkSurface adhesive is not forced from the join, these areas will be weak spots and step 6 needs to be repeated.
9. Clamp SilkSurface together but do not overtighten. If all adhesive is forced out the seam will become 'dry' and won't have any strength. The recommended final seam thickness is 0.3-0.5mm.
10. Double check the SilkSurface slabs are aligned and level. If required, use a rubber mallet to adjust.
11. Allow adhesive to cure before removing clamps (45mins curing time between 16-24 degrees Celsius. In temperatures cooler than 16 degrees, the adhesive will take longer to cure).
12. Remove excess adhesive with a portable handheld router on rails or a block planer (avoid using chisels).
13. Refer to 'Finishing/Polishing' section for final surfacing detail.
14. We recommend sanding & polishing joins upon installation.
15. It is up to the fabricator to find the best match for the slabs to join, before cutting of the slabs and installation. This is industry standard.

Reinforcing the seam

When using SilkSurface adhesive and following the recommended procedures to join SilkSurface a seam reinforcement is not required. The only exception to this rule is if heavy items will be placed directly over or near the seam in which case the below steps can be followed to provide the necessary strength to the join. Do not apply reinforcement to a seam that is still curing.

1. Cut 50mm wide strips of SilkSurface to run as far as possible along the length of the seam.
2. Roughen the face of the 50mm strip to be joined and the underside of the seam with 120 Grit sandpaper.
3. Ensure all dust and excess material is removed with a lint free white rag and methylated spirits.
4. Apply a minimum 3mm bead of SilkSurface adhesive across the entire roughened face of the SilkSurface.
5. Clamp the support piece into place on the underside of the seam until the adhesive has cured (45mins curing time between 16-24 degrees Celsius. In temperatures cooler than 16 degrees, the adhesive will take longer to cure).

Built up edges

There are several different built-up edge options for SilkSurface. The choice of one of the following options will depend on the veining/pattern of the chosen SilkSurface colour, the tooling available and the desired edge thickness and finish. It is important to confirm the thickness of the SilkSurface slabs prior to beginning edge work as there may be slight variation from the standard 20mm slab thickness.

For fabricators who have not worked with SilkSurface/SilkSurface adhesive or used a certain built up edge method previously, it is recommended that small offcuts are used to test your preferred built up edge option to ensure production can be completed smoothly and correctly for larger pieces.

Mitred (V-Groove)



1. Using a 90V Router bit (per tooling specifications) or a V grooving machine, create a 45-degree angle on both slab edges to be joined.
2. With a biscuit joining machine (for eg. Lamello Zeta P2) create 50mm wide by 5mm deep routes along the entire V groove edge at maximum 100mm spacing (between route centres). These routes provide additional surface area for the adhesive to bind to creating a strong joint.
3. Using 120 Grit sandpaper, roughen the faces of the V groove edge making sure that the outside edges of the slab remain sharp for a clean join. Repeat this step 2-3 times across the length of the join for both Slabs.
4. Ensure all dust and excess material is removed with a lint free white rag and methylated spirits.
5. Apply colour matching SilkSurface adhesive evenly and consistently along the length of one of the V groove edges (it is recommended that adhesive is applied to the edge of the larger SilkSurface slab to be joined as it may be easier to clamp smaller pieces to a large slab rather than larger pieces to a small slab) Minimise air bubbles by applying adhesive continuously without stopping, a minimum 3mm thick bead of adhesive is required for a secure joint.
6. Place SilkSurface built up edge pieces in position, double check it is correctly aligned and clamp down (Mitre clamps or a 90-degree frame can assist in holding the pieces together securely and in alignment). Ensure an even line of adhesive is squeezed out from each edge of the joint otherwise weak spots will be created. If necessary, repeat Step 4 and apply further adhesive. SilkSurface adhesive will begin to cure rapidly so ensure that adhesive is applied, and the built-up edge pieces are in position and clamped as soon as possible. Do not overtighten clamps as if all adhesive is forced out the seam will become 'dry' and won't have any strength, the recommended final seam thickness is 0.3-0.5mm.
7. Allow adhesive to cure before removing clamps (45mins curing time between 16-24 degrees Celsius. In temperatures cooler than 16 degrees, the adhesive will take longer to cure).
8. Remove excess adhesive with a portable handheld router on rails or a block planer (avoid using chisels).
9. Refer to 'Finishing/Polishing' section for the final surface finish procedure.

Drop edge (Rebate)



This method requires the SilkSurface Slab top to be 1mm oversized for each edge that will be built up (As 1mm will be removed as part the finishing process).

1. Route edges of the bottom face of the Silk slab which will have a built-up edge applied. The route depth should be 4mm thinner than the thickness of the slab (usually a 16mm deep route for 20mm thick SilkSurface slab) and 1mm wider than the thickness of the SilkSurface slab (usually a 21mm width route).
2. Using 120 Grit sandpaper, roughen the routed bottom edge of the SilkSurface slab and the top and back edge of the built-up edge SilkSurface piece.
3. Ensure all dust and excess material is removed with a lint free white rag and methylated spirits.
4. Apply colour matching SilkSurface adhesive evenly and consistently along the length of the route. Minimise air bubbles by applying adhesive continuously along the entire length of the route. A minimum 3mm thick bead of adhesive is required for a secure joint.
5. Place SilkSurface built up edge piece in position, double check it is correctly aligned and clamp down. Ensure an even line of adhesive is squeezed out from both the front and back edge of the joint otherwise weak spots will be created. If necessary, repeat from Step 4 and apply further adhesive. SilkSurface adhesive will begin to cure rapidly so ensure that adhesive is applied, and the built-up edge pieces are in position and clamped as soon as possible. Do not overtighten clamps as if all adhesive is forced out the seam will become 'dry' and won't have any strength, the recommended final seam thickness is 0.3-0.5mm.
6. Allow adhesive to cure before removing clamps (45mins curing time between 16-24 degrees Celsius. In temperatures cooler than 16 degrees, the adhesive will take longer to cure).
7. Remove excess adhesive with a portable handheld router on rails or a block planer (avoid using chisels).
8. Refer to 'Finishing/Polishing' section for the final surface finish procedure.

Drop edge (No rebate)



1. Using 120 Grit sandpaper, roughen the routed bottom edge of the SilkSurface slab and the top edge of the built-up edge piece.
2. Ensure all dust and excess material is removed with a lint free white rag and methylated spirits.
3. To keep built-up edge panel aligned to the Top slab edge, it is recommended that MDF blocks are hot melt glued in position on the underside of the top, set back the thickness of the slab. (Hot melt glue enables the MDF blocks to be easily removed after the SilkSurface adhesive for the built-up edge has cured).
4. Apply colour matching SilkSurface adhesive evenly and consistently along the length of the route. Minimise air bubbles by applying adhesive continuously along the entire length of the route, a minimum 3mm thick bead of adhesive is required for a secure joint.
5. Place SilkSurface built-up edge piece in position, double check it is correctly aligned and clamp down. Ensure an even line of adhesive is squeezed out from all edges of the joint otherwise weak spots will be created. If necessary, repeat from Step 4 and apply further adhesive. SilkSurface adhesive will begin to cure rapidly so ensure that adhesive is applied, and the built-up edge pieces are in position and clamped as soon as possible. Do not overtighten clamps as if all adhesive is forced out the seam will become 'dry' and won't have any strength, the recommended final seam thickness is 0.3-0.5mm.
6. Allow adhesive to cure before removing clamps (45mins curing time between 16-24 degrees Celsius. In temperatures cooler than 16 degrees, the adhesive will take longer to cure).
7. Remove excess adhesive with a portable handheld router on rails or a block planer (avoid using chisels).
8. Refer to 'Finishing/Polishing' section for the final surface finish procedure.

Stacked edge

(Not recommended for colours with defined veining)

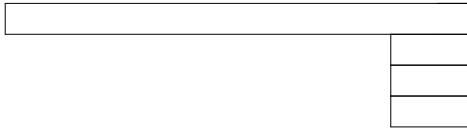

The recommended width of stacked SilkSurface edge is 50mm and it can be built up in 20mm increments (Slab Thickness).

1. Using 120 Grit sandpaper, roughen the bottom edge of the SilkSurface slab and the top edge of the built-up stacked piece. If multiple pieces of SilkSurface are being stacked, then the top of bottom of each piece needs to be roughened (any face that will then have SilkSurface adhesive applied to it).
2. Ensure all dust and excess material is removed with a lint free white rag and methylated spirits.
3. To keep stacked SilkSurface panels aligned to the slab edge, it is recommended that MDF blocks are hot melt glued in position on the underside of the top, set back the width of the stack SilkSurface pieces). (Hot melt glue enables the MDF blocks to be easily removed after the SilkSurface adhesive for the built-up edge has cured).
4. Apply colour matching SilkSurface adhesive evenly and consistently along the roughened face of the built-up stacked SilkSurface piece. A minimum 3mm thick bead of adhesive is required for a secure joint.
5. Place SilkSurface built up edge piece in position, double check it is correctly aligned and clamp down. Ensure an even line of adhesive is squeezed out each edge of the joint otherwise weak spots will remain. If necessary, repeat from Step 4. SilkSurface adhesive will begin to cure rapidly so ensure that adhesive is applied, and the stacked edge pieces are in position and clamped as soon as possible. Do not overtighten clamps as if all adhesive is forced out the seam will become 'dry' and won't have any strength. The recommended final seam thickness is 0.3-0.5mm.
6. Allow adhesive to cure before removing clamps (45mins curing time between 16-24 degrees Celsius. In temperatures cooler than 16 degrees, adhesive will take longer to cure).
7. Repeat steps 4 to 6 for each piece of SilkSurface that is creating the built-up edge (If more than one).
8. Remove excess adhesive with a portable handheld router on rails or a block planer (avoid using chisels).
9. Refer to 'Finishing/Polishing' section for the final surface finish procedure.

Refer to 'Built-up Edge Support' subsection of 'Supports and Subframes' for additional information regarding built-up edges and supports required.

Supports and subframes

Never screw directly into SilkSurface to affix supports or subframes. Supports or subframes can be secured to SilkSurface using a silicone adhesive.

As a 20mm Slab Top, SilkSurface does not need additional support or a subframe as long as the structure the slab is mounted to is constructed so that the SilkSurface is supported at maximum 900mm intervals across the length and 600mm across the depth of the slab (As per below). Any cutouts (Sink, Cooktop, etc.) require support within 150mm from the edge of the cutout.

Consideration should also be made when planning openings (Dishwashers, dryers etc.) to ensure the supports do not extend past the maximum 900mm spacing.

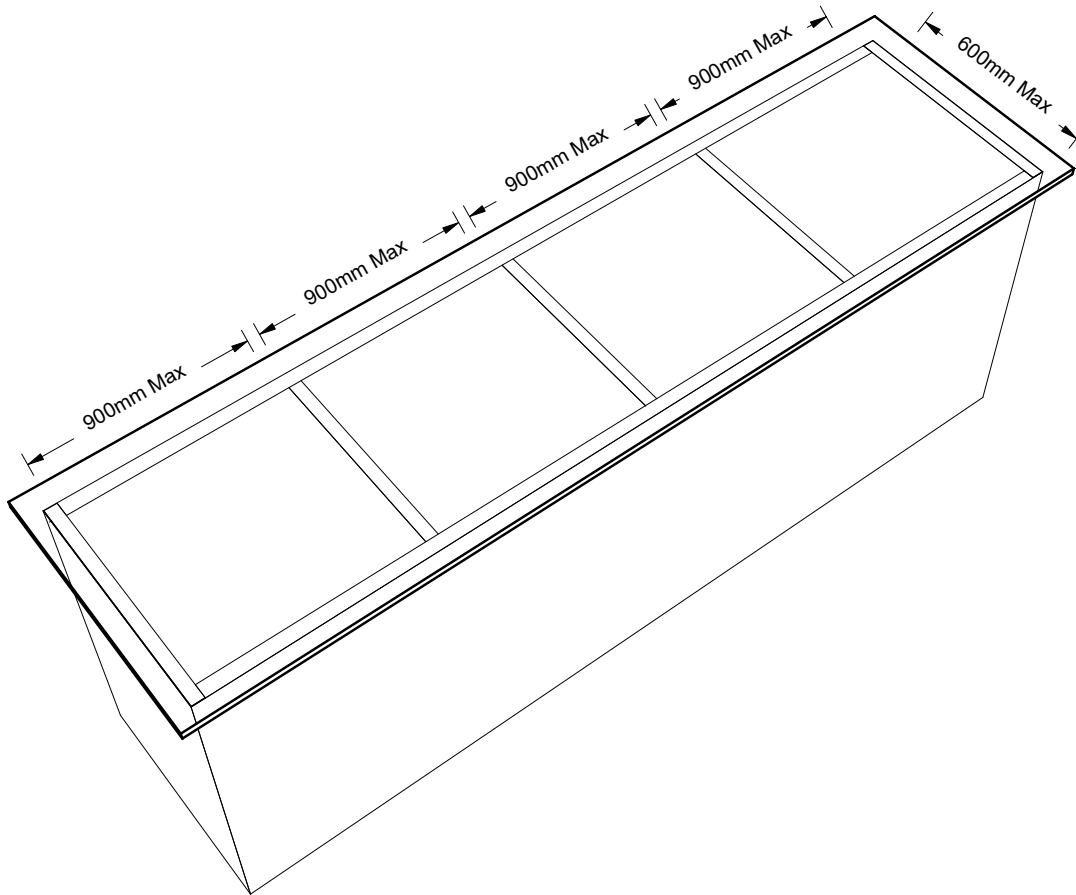

For a SilkSurface Slab with built up edges, a subframe may need to be constructed to ensure the maximum 900mm spacing between supports of the SilkSurface top slab is achieved. Depending on the material best suited to the application, subframes can be constructed out of metal (Aluminium/Steel) or timber (MDF/Particleboard).

SilkSurface overhang support

When a SilkSurface Slabs extends further than 300mm out from the mounting surface, additional support is required for the overhang.

- When fixing an island bench onsite to the joinery, highly recommend fixing to all possible parts of the subframe (cabinets below).
- Securely glued at all possible contact points with the joinery below
- 0-300mm Overhang: No support required.
- 300-450mm Overhang: Corbels or L Shape Corner brackets that reach to a maximum 150mm from the edge of the overhang. SilkSurface can also be fabricated into a corbel to serve as a support)
- 450mm-600mm Overhang: Legs or other support that runs from the underside of the SilkSurface to the floor. These supports must not exceed 600mm spacings.
- Common support options are:
 - o Anchored on one side to a wall
 - o Waterfall ends can serve as supports on either side of island benches.
 - o Brackets can be rebated into SilkSurface for additional support if needed.

Built-up edge support

For mitred edges, if a built-up edge is larger than 50mm in height and does not have any structural support on the underside of the SilkSurface slab, then additional support will be required. Stacked edge profiles do not require any additional support.

Support can be achieved by fixing L shape corner brackets to the underside of the SilkSurface Slab/Built up edge with SilkSurface adhesive. The brackets must be designed to keep a joint at 90 degrees and should be mounted at maximum 600mm spacings.

Where L shape brackets aren't suitable, support of larger built-up edges can also be achieved using SilkSurface offcuts.

1. Using 120 Grit sandpaper, roughen the routed bottom edges of the SilkSurface slab at position of the supports and roughen the two edges of the SilkSurface support pieces that will have SilkSurface adhesive applied to them.
2. Ensure all dust and excess material is removed with a lint free white rag and methylated spirits.
3. Apply colour matching SilkSurface adhesive evenly and consistently along the roughened edges of the SilkSurface support pieces. A minimum 3mm thick bead of adhesive is required for a secure joint.
4. Place SilkSurface support pieces in position and clamp down. Ensure an even line of adhesive is squeezed out each edge of the joint otherwise weak spots will remain. If necessary, repeat from Step 3 and apply further adhesive. SilkSurface adhesive will begin to cure rapidly so ensure that adhesive is applied, and the support pieces are in position and clamped as soon as possible. Do not overtighten clamps as if all adhesive is forced out the seam will become 'dry' and won't have any strength, the recommended final seam thickness is 0.3-0.5mm.
5. Allow adhesive to cure before removing clamps (45mins curing time between 16-24 degrees Celsius. In temperatures cooler than 16 degrees, the adhesive will take longer to cure).

Cutouts

Cutouts within SilkSurface (Sink, Cooktop etc.) can be completed either by a CNC or hand router making sure the recommended tooling is used.

- If routing by hand, it is recommended that a MDF template of the cutout is created and clamped in position for a clean and accurate cut.
- A minimum 5mm inside corner radius is required for all cutouts to prevent weak areas susceptible to cracking.
- As noted in the 'Transportation, Site Preparation and Installation' section, cutouts need adequate support to prevent cracking or warping prior to installation.
- Heat tape is not a requirement, however some fabricators / installers like to use heat tape as a precaution / peace of mind.

Finishing and polishing

To achieve a flawless finish, the following guide should be used when finishing/polishing SilkSurface. SilkSurface slabs are supplied with a 4K Gloss finish to the face which can be repolished to a Matt or Semi-gloss finish if required. In addition to polishing the edges of a fabricated SilkSurface top to a matching finish, after storage, machining, and fabrication the slab face may need to be repolished to be brought back to its original finish.

- The random orbital sander should be moved in small clockwise circles while moving left to right, front to back or diagonally across the top. Ensure to overlap movements of the orbital sander by at least half the width of the sanding pad.
- Do not skip a sandpaper grit during the process (each sandpaper grit listed at the bottom of this section should be used)
- Ensure all dust is removed with a clean white rag and water between each sanding run or grit change.
- Ensure the entire slab surface is gone over at least 3 times with each grit sandpaper.
- Apply consistent even pressure with the sander across the face of the SilkSurface and keep the Random orbital sander level.
- Ensure Sandpaper is changed as it becomes worn/clogged.
- To maximise scratch resistance and keep your surface looking pristine, we recommend finishing your benchtops with our SilkSurface Polish & Cleaner.

The below table specifies the sandpaper required for each finish type:

Finish	P Grade Sandpaper
Matt	P180, P240, P320, P500
Semi-Gloss	P180, P240, P320, P500, P800, P1000 (Cutting), P1000 (Polishing)
Gloss (4K)	P180, P240, P320, P500, P800, P1000 (Cutting), P1000 (Polishing), P2000 (Polishing), P3000 (Polishing), P4000 (Polishing)

Transportation, site preparation and installation

Transportation to site

- Ensure SilkSurface Tops are properly wrapped in bubble wrap, foam, corrugated cardboard, or furniture blankets. Each SilkSurface top must be wrapped individually as tops transported touching each other may reach site scratched or chipped if dust or other particles are between the surfaces.
- When transporting either horizontally or vertically, the SilkSurface top must have support across the full length at maximum 600mm spacing to prevent warping.
- Ensure any cutouts have the support necessary to prevent cracking during transport.
- SilkSurface tops must be secured in place so there is no movement during transport that may result in damage.

Site preparation and installation

- Ensure the correct personal protective equipment (PPE) is worn and manual handling procedures are followed correctly throughout the installation process (Refer to 'Handling' section).
- Ensure that the surface the SilkSurface top will be mounted to is flat and level.
- Ensure that mounting surface has necessary support for SilkSurface (Refer to 'Supports' section).
- Unwrap SilkSurface and quality check for any damage that may have occurred during transportation.
- Test fit SilkSurface tops without applying adhesive to ensure a correct fit. Ensure an expansion gap of 1.5-3mm is left between walls which can be sealed with a silicone sealant if needed. If required, the SilkSurface top can be scribed into place using an electric planer, a router or belt sander.
- Complete any onsite seaming/joining following procedure set out in 'Cutting/Joining SilkSurface' section.
- Per 'Finishing and Polishing' section, finish any onsite seams or other surfaces that were not able to be completed prior to installation.
- Prior to fixing SilkSurface slabs to the mounting surface (E.g. Cabinetry) ensure that both surfaces are clean and free from dust.
- Never screw directly into SilkSurface. SilkSurface can be secured to the mounting surface in two ways:
 - o A silicone adhesive directly between the SilkSurface slab and mounting surface
 - o Screwing through the mounting surface into a timber frame that has been fixed to the underside of the SilkSurface.
- Once installation is completed, Quality check all surfaces and protect finished surfaces with a protective sheeting.
- Heat tape is not a requirement, however some fabricators / installers like to use heat tape as a precaution / peace of mind.
- SilkSurface comes with a protective clear film. If protecting the benchtop onsite from other trades – clear protective film is recommended.
- We recommend supplying your customer with one of our Care Kits as part of your handover process.

Repair

SilkSurface is a highly repairable product and when completed correctly can be restored back to its original state. The below steps outline the procedures for repairing SilkSurface if damage occurs.

Scratches and minor surface marks

Minor scratches, stains or shallow impact marks can be polished out by following the steps laid out in 'Finishing/Polishing' section. For light scratches, start at P320 grit sandpaper and sequentially move up finer grits listed until the desired finish (Matt, Semi-gloss, Gloss) is reached. Deeper scratches may require at a coarser grit sandpaper (P180) to be used as the starting point.

Deeper surface marks and small chips

For deeper surface marks and chips where re-polishing the surface will not be sufficient, it is possible to repair the damage with SilkSurface adhesive that matches the SilkSurface slab colour.

1. Drill out the damaged area using a diamond tipped drill (recommended) or tungsten carbide drill bit. The size of the damage will determine the diameter drill bit required, however any damage over 5mm wide consider if a 'plug repair' method (see below) is better suited.
2. Ensure all dust and excess material is removed from the drill hole and clean with a lint free white rag and methylated spirits.
3. Fill the hole with matching SilkSurface adhesive ensuring to overfill the hole so that the repaired surface can be polished down to the flat surface of the rest of the slab.
4. Once cured, follow the steps laid out in Finishing/Polishing section to reach the required finish (Matte, Semi-gloss, or Gloss). Ensure to blend the polishing area outside of the repaired section to achieve a uniform finish.

Cracks and major surface damage

For major damage or cracks, the damaged area will have to be completely removed and replaced with a matching SilkSurface piece.

1. Depending on the damaged area and the veining/pattern in the SilkSurface, determine the size of the repair.
2. Create a MDF Template the size and shape of the replacement piece and clamp it in place around the damaged area.
3. Using a hand router remove the damaged area from the SilkSurface Slab.
4. Using the same MDF template, machine a replacement SilkSurface piece from a new SilkSurface slab that matches or an offcut from the original job.
5. Test fit the replacement SilkSurface piece to ensure a clean join.
6. Ensure edges of both the cutout section and replacement are clean and free from dust, cleaning with a lint free white rag and methylated spirits if required.
7. Using matching SilkSurface adhesive, attach the replacement piece to the cutout.
8. Once cured, follow the steps laid out in Finishing/Polishing section to reach the required finish (Matte, Semi-gloss, or Gloss). Ensure to blend the polishing area outside of the repaired section to achieve a uniform finish.

Broken seams

In the case of a broken or damaged seam, using a 6mm router bit with the recommended tool specifications, remove the seam to the required depth and fit a new 6mm SilkSurface piece in place following the steps laid out in 'Applying adhesive/Joining SilkSurface' section. Consider the veining of both the existing slabs and the replacement SilkSurface piece before starting.

Water hardness

Hard water can leave temporary watermarks on SilkSurface, which can be removed with CLR Bathroom & Kitchen Action Cleaner or similar.

Why we get colour variation in the solid surface industry?

- Sometimes you will have slabs from the same batch put end to end and they will be different, however when you turn one slab around the ends will match. This is due to light refraction.
- If you have an L shaped kitchen plan with 1 of 3 walls with a window, the light refraction can make the joined slabs look a different colour when in actual fact this is due to light refraction.
- 5% tonal difference is the accepted standard in the industry.
- Edge to edge is not always the best way to join slabs at a 90 degree joint. You have a better chance of matching slabs seamlessly by using a masons mitre. A masons mitre also has a 90% better chance of not cracking over time.
- Distribution of ingredients and the orientation of particles can also be a cause.
- It is up to the fabricator to find the best match for the slabs to join, before cutting of the slabs and installation. This is industry standard.

Versatile applications

- BBQ & Alfresco Areas: SilkSurface is suitable for outdoor applications when installed under a roof, protecting it from full exposure to harsh conditions. Warranty coverage applies only to areas with overhead shelter.
- Translucent colours are not recommended for outdoor use as those colours require higher resin content and less solids where the sun penetrates deeper into the colour and causes discolouration even though it has been UV stabilized.
- Whiter colours are the best for outdoor use due to the high solid content, high titanium content and lack of penetration from UV rays.
- Standard and Deluxe Ranges are suitable for laboratory applications.
- Splashbacks behind vanities.
- Splashbacks in kitchens / behind cooking surfaces (with recommended clearances).
- Bathroom / wet-area shelves, niches and nibs.
- Stair treads.
- Customer furniture such as built-in entertainment units, dining or coffee table tops.



The SilkSurface University

Become a change maker with FREE SilkSurface training for your business.

The possibilities with SilkSurface for you and your clients really are endless and so we're on a mission to provide training and support to get you started on your own journey.

The SilkSurface University is a fun and totally free training day where you get to learn from the team who have developed our range.

Learn the basics right through to the innovative ways SilkSurface can open creative and business opportunities for you.

The university runs monthly, so reach out and call **02 6773 8510** or email sales@silksurface.com.au to secure your spot today.

"The day opened up a whole range of possibilities for our clients and our business, thank you" Matt, a recent graduate.



Access a range of helpful
SilkSurface video resources.

SilkSurface™

sales@silksurface.com.au | 02 6773 8510 | 22 Myrtle Drive, Armidale New South Wales 2350
www.silksurface.com.au

MARCH 2025